

DB, L, XL 400, 25, 50, 75

DOLPHIN PANEL MOUNTED INFRARED TAP

INSTALLATION AND MAINTENANCE GUIDE

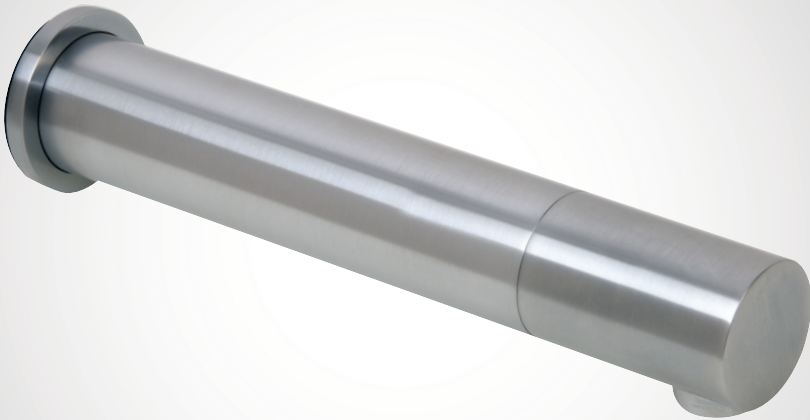

January 2020



CONTENTS

- 3 Technical Data
- 4 Pack Contents
- 5 Pre-Installation Information
- 7 - 9 Tap Installation
- 10 - 12 Settings Adjustment
- 13 Battery Replacement Instructions
- 14 Maintenance
 - Filters Cleaning Instructions
 - Care and Cleaning of Chrome and Special Finishes
- 15 Spare Parts
- 16 Limited Warranty
- 17 Troubleshooting

TECHNICAL DATA

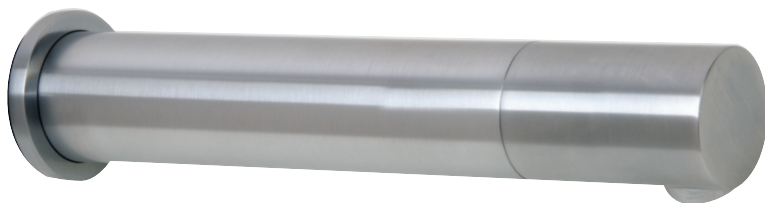

Wall mounted electronic tap for cold or premixed water

Power Supply

Battery	6x1.5AA battery (DB/L/XL 400 models)
Transformer	9v transformer (DB/L/XL 425 + DB 475 models)

Recommended 0.5-8.0 bar (7-116 PSI)

Water Pressure With water pressure of more than 8 bars use a pressure reducing valve

Sensor range Self adjusting sensor. Adjustable with remote control

Minimum sensor range 80mm

Maximum sensor range 300mm

Security time 90 seconds Can be changed with the DB51 remote control

Hot water temperature Max 70°C

PACK CONTENTS

DB, L, XL 400, 25, 50, 75

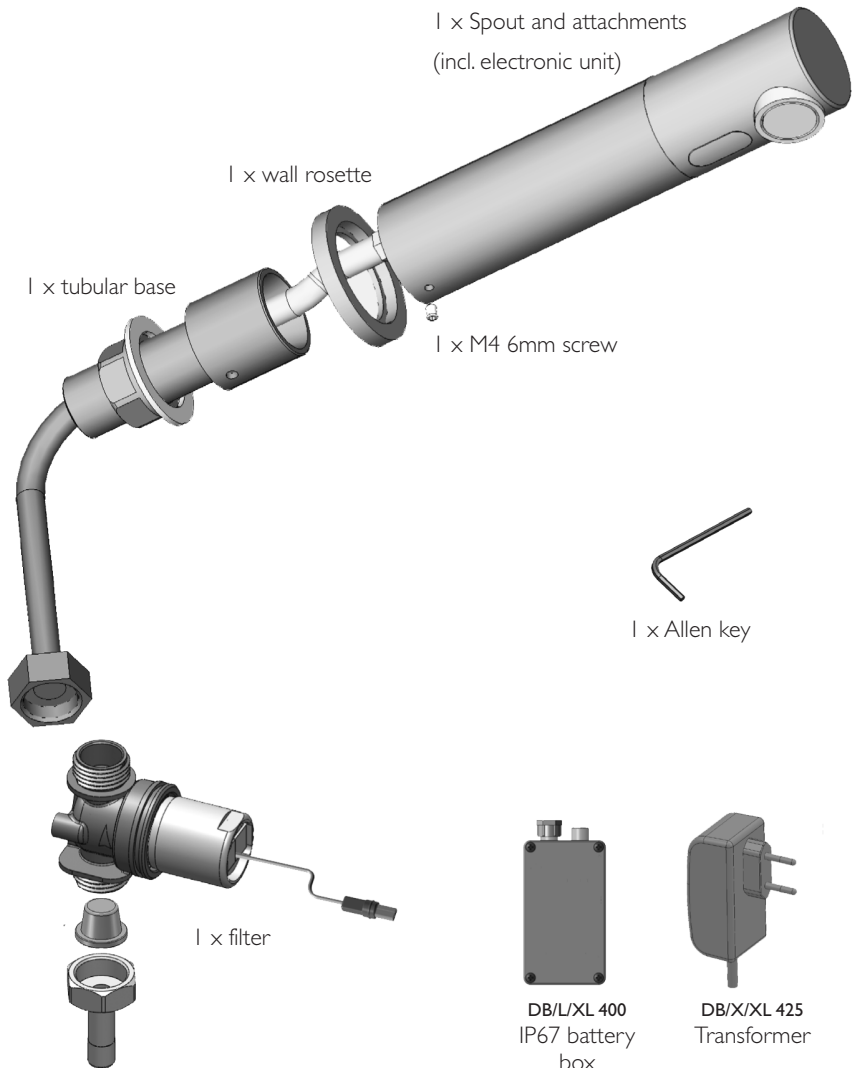

PRE INSTALLATION INFORMATION

CHECK CONTENTS

- › Separate all parts from the packaging and check you have each part according to the pack contents section, pages 4-6. Pay attention to the variations of the different models.
- › Make sure all parts are accounted for before discarding any packaging material.
- › If any parts are missing, do not attempt to install your electronic tap. Please call 0800 0723 404 immediately to notify us.

WARNING

- › To avoid reflection problems keep a distance of more than 300 mm. between the sink and the spout.
- › This tap model, with an infrared sensor pointing down, is not intended to be used together with a sink of a reflective material such as stainless steel.
- › If a sink strainer is straight below the tap sensor, use a strainer with a non reflective finish (do not use a chrome plated one).

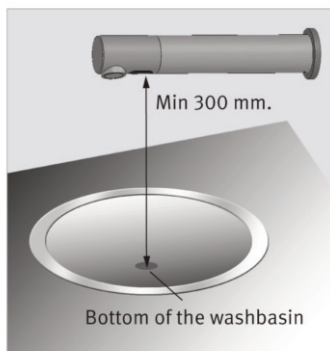

PREPARATION FOR INSTALLATION

- › Flush water supply lines thoroughly before installing the tap.
- › Do not allow dirt, Teflon tape or metal particles to enter the tap.
- › Shut off water supply.

Important All plumbing is to be installed in accordance with applicable codes and regulations.

PRE INSTALLATION INFORMATION

WARNING

- › Highly reflective surfaces directly beneath the sensor of this product, in particular polished finish basin wastes/ strainers, will cause false activation of the infrared sensors and can result in malfunction. We recommend satin or matt finish products which can be found on our website.
- › It is very important to allow permanent access to the mounting tail/nut of this product for future servicing and repair. Where this is not possible see our wall plate mounted products.
- › To avoid reflection problems it is recommended to keep a distance of more than 300mm between the sink and the spout. If the distance is below 300mm a simple mock-up should be effected to confirm the tap functions as desired in your application before final installation. You may require a Dolphin Blue remote control to adjust the range.
- › Do not connect water or power supplies or remove the black label covering the infrared sensor until you have read and understood these instructions. Please see page 13.
- › It is not recommended to use DB400 series with a polished stainless steel sink. For this type of application a separate panel-mounted sensor should be used – please speak to our technical sales team.
- › Please observe the guide to minimum cavity depths as shown in the table. This is important because the water supply hose must not be kinked due to lack of space. Please note we have provided this information as a guide and cannot be held responsible for fundamental design errors. If your situation differs to those shown below please call us on 0800 0723 404, and we will provide you with a solution.

Panel thickness (A)	Minimum void (B)
10-15mm	90mm
16-25mm	80mm
26-35mm	70mm

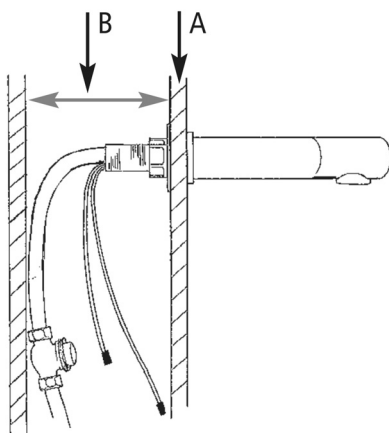

TAP INSTALLATION

INSTALLATION INSTRUCTIONS FOR DB/L/XL 400 + DB/L/XL 425

STEP I – INSTALLING THE TAP

1. Shut off the water supply
2. Drill a hole (23 to 24 mm) at the place where you want to install the spout of the tap.
3. If your model includes an optional anti-rotation pin, drill a small hole just above the previous one for the anti-rotation pin.

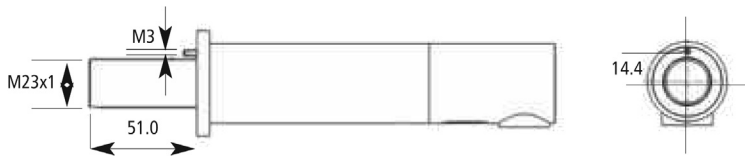

4. Insert the tap and its attachments through the wall. The aerator at the tap spout must face the washbasin.
5. Insert the anti-rotation pin into the small hole (if needed)
6. Fix the base behind the wall with the hexagonal nut and the disk.

TAP INSTALLATION

STEP 2 – CONNECTING THE WATER SUPPLY

1. Fit the flexible pipe coming from the Tap base to the solenoid valve housing.
2. Fit the water supply inlet to the adapter at the solenoid valve housing. Inlet and outlet should follow the indicating arrow at the solenoid housing.

Note: Make sure the filter is located at the solenoid inlet.

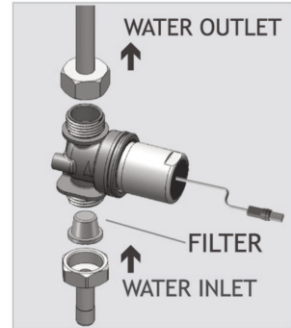

3. Connect the cable coming from the electronic unit to the solenoid valve.

Important: Tap was supplied with a Self Adjusting Sensor. The ideal sensor range for the specific location will be set automatically.

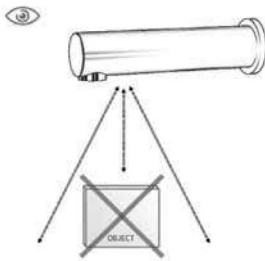

Before proceeding to step 3 check that no objects are in front of the sensor besides the washbasin.



Now, remove the protecting sticker that covers the sensor.

TAP INSTALLATION

STEP 3 – CONNECTING THE POWER SOURCE

1a. For DB/L/XL 400: Connect the other cable coming from the electronic unit at the Tap base to the battery box.

1b. For DB/L/XL 425: Connect the other cable coming from the electronic unit at the Tap base to the transformer. Plug the transformer into the electricity socket.

2. After you have connected the power source (Battery or Transformer) wait 15 seconds in order to allow the system to set the ideal sensor range.

As an indication that the self adjusting is taking place, a red light in the sensor eye will flash continuously. The solenoid valve will be opened and closed for 1 second as an indication that the ideal sensor range was set and the product is ready for use.

3. Turn on the central water supply. Check for leaks.

Note: This tap includes a special aerator that allows you to adjust the water stream direction on site in order to prevent water splashing if needed. To change the angle of the water stream, simply move the adjustable tilting plate by pressing it smoothly.

4. If the automatically adjusted sensor range is not satisfactory, please refer to the section entitled "Settings adjustment".

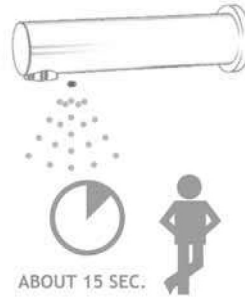

SETTING ADJUSTMENT



ADJUSTING THE SENSOR WITH THE REMOTE CONTROL

If necessary, the sensor settings can be adjusted as following:

Shut off the water supply. In order to adjust the sensor with the remote control, hold the remote control straight in front of the sensor in a distance of about 6-8'' (15-20cm).

Choose the function you want to adjust by pressing once on one of the function buttons. After pressing once on a specific function button, a quick flashing of the LED at the front of the sensor will occur. At this stage, you can change the setting by pressing the (+) or the (-) buttons, every push will increase or decrease one level. After finishing the adjustment, turn the water supply back on.

SETTING ADJUSTMENT



DETECTION RANGE: This tap was supplied with a Self Adjusting Sensor. The ideal detection range for the specific location will be set automatically. **Only if necessary**, use the remote control to adjust the sensor range as follows:

Press the RANGE button. Wait until a quick flashing of the red light of the sensor eye is perceived. Then, press + to increase the one level and – to reduce it every push will increase or decrease one level.

Note: Once you have changed the detection range with the remote control, this distance will be remembered by the sensor, even if the power source is disconnected. To get back to the self adjustment mode, use the ADJ button only.



ENTRANCE TO THE SELF ADJUSTMENT MODE:

Check that no objects are in front of the sensor. Press the ADJ button. Once a quick flashing of the red light of the sensor eye is perceived, remove your hand holding the remote control and move away from the sensor area. The ideal sensor range for the specific location will be set automatically. Once the self adjustment has taken place the solenoid valve will be opened and closed for 1 second as an indication that the ideal sensor range was set and the product is ready for use.



SECURITY TIME: The Security time, prevents continuous running of water due to reflections or vandalism. By default, if the sensor is covered for more than 90 seconds the water flow will shut automatically. To resume regular operation any obstruction must be removed.

Press the SEC button. Wait until a quick flashing of the red light of the sensor eye is perceived. Then, press + to increase the security time and – to reduce it.

SETTING ADJUSTMENT



DELAY IN TIME: It is recommended to change the delay in time for flush valves for urinals or toilets only.

If required, the delay in time can also be modified in taps as follows: Press the IN button. Wait until a quick flashing of the red light of the sensor eye is perceived. Then, press + to increase the delay in time and - to reduce it.



DELAY OUT TIME: This button allows modifying the water flow time after the user removes his hands from the tap. A delay out time close to 0 will save more water. An increased delay out time will make the user experience more comfortable.

If required, the delay out time can be modified as follows: Press the OUT button. Wait until a quick flashing of the red light of the sensor eye is perceived. Then, press + to increase the delay out time and - to reduce it.



TEMPORARY OFF FUNCTION: This function is ideal to perform any kind of activity in front of the sensor without operating the system (for example, cleaning). The tap will remain shut for 1 minute when this button is pressed once. To cancel this function and to return to normal operation press the On/Off button again or wait 1 minute.



RESET BUTTON: This function restores all the factory settings except for the sensor range. If required, press the Reset button and without releasing it, press the + button once.

Note: To enter the self adjusting mode, use the ADJ button. To change the sensor range, use the RANGE button.

BATTERY REPLACEMENT

BATTERY MODELS ONLY

When the battery weakens, the red indicator light will blink at a constant rate when the user's hands are within the sensor range. The battery must be replaced within two weeks.

To replace the battery (battery models only):

For DB/L/XL 400: Open carefully the batteries' box and remove the old batteries. Replace the used batteries with six new 1.5V AA batteries. Close the box.

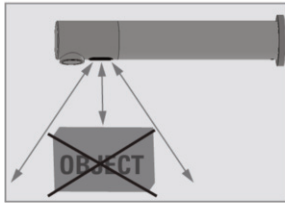

Check that there are no objects in front of the sensor after the battery replacement was completed.



After you have replaced the battery, move away from the sensor range. Wait 15 seconds in order to allow the system to set the ideal sensor range. Then after the self adjustment has taken place the solenoid valve will be opened and closed for 1 second as an indication that the ideal sensor range was set and the product is ready for use.

Important: Spent batteries should not be disposed of with normal household waste. Contact your local authority for information on waste disposal and recycling, changing the battery.



MAINTENANCE

FILTER CLEANING INSTRUCTION

This tap is provided with a stainless steel filter preventing foreign particles to enter the lines. If the water flow has decreased, this may be because the filter is clogged. The filter can be cleaned as follows:

For DB/X/XL 400 + 425:

- a. Shut-off the water shut off valve.
- b. Disconnect the water supply pipe from the adaptor and disassemble the filter from it.
- c. Wash the filter under running water.
- d. Reassemble the parts.
- e. Restore the incoming water supply.
- f. Make sure that there is no water leakage.

CARE AND CLEANING OF CHROME AND SPECIAL FINISHES

DO NOT use steel wool or cleansing agents containing alcohol, acid, abrasives, or the like. Use of any prohibited cleaning or maintenance products or substances could damage the surface of the tap. For surface cleaning of tap use **ONLY** soap and water; then wipe dry with clean cloth or towel. When cleaning bathroom tile, the taps should be protected from any splattering of harsh cleansers.

SPARE PARTS LIST

Self adjusting sensor kit	DB07220239
Solenoid valve kit.....	DB07230017
Solenoid housing kit for DB/L/XL 400 + 425.....	DB07231008
Transformer	DB85M
IP67 Battery box	DB83M
Diaphragm	DB04500001

Optional accessories

Remote control	DB51
Battery box for 1 x 9v battery	DB82M
IP67 Transformer box - unterminated (no plug)	DB69M
Junction Box for up to 10 products	D87
Transformer junction box exit with 3 meter cable and male connector:	DB06000084
TMV Mixing valve	AL0220

LIMITED WARRANTY

Dolphin Solutions Ltd. warrants that its electronic products will be free of defects in material and workmanship during normal use for two years from the date the product is purchased.

If a defect is found in normal use, Dolphin Solutions Ltd. will, at its discretion, repair, provide a replacement part or product, or make appropriate adjustments. Damage caused by accident, misuse, or abuse is not covered by this warranty. Improper care and cleaning will void the warranty. Proof of purchase (original sales receipt) must be provided to Dolphin Solutions Ltd. with all warranty claims.

Dolphin Solutions Ltd. is not responsible for labor charges, installation, or other incidental or consequential costs other than those noted above. In no event shall the liability of Dolphin Solutions Ltd. exceed the purchase price of the product.

If you believe that you have a warranty claim, contact your Dolphin Distributor, Dealer or Plumbing Contractor. Please be sure to provide all pertinent information regarding your claim, including a complete description of the problem, the product, model number, the date the product was purchased, from whom the product was purchased and the installation date. Also include your original invoice.

DOLPHIN SOLUTIONS LTD. AND/OR SELER DISCLAIM ANY LIABILITY FOR SPECIAL, INCIDENTAL OR CONSEQUENTIAL DAMAGES. This warranty excludes product damage due to installation error; incorrect maintenance, wear and tear, battery, product abuse, or product misuse, whether performed by a contractor; service company, or the consumer. This warranty does not cover product damage caused by the following:

- > Incorrect installation.
- > Inversions of supply pipes.
- > Pressures or temperatures exceeding recommended limits.
- > Improper manipulation, tampering, bad or lapsed maintenance.
- > Foreign bodies, dirt or scale introduced by the water supply.

TROUBLE SHOOTING

PROBLEM	INDICATOR	CAUSE	SOLUTION
No water coming out of the faucet:	1. Sensor flashes continuously when user's hands are within the sensor's range.	Low battery.	Replace battery
	2. Red light in the sensor does not flash once when user's hands are within the sensor's range.	1. Range is too short.	Increase the range
		2. Range is too long.	Decrease the range
		3. Battery is completely used up	The battery must be replaced.
		4. Unit is in "Security Mode"*	
3. Red light in the sensor flashes once when user's hands are within the sensor's range.	5. Sensor is picking up reflections from the washbasin or another object.	Eliminate cause of reflection.	
	1. Debris or scale in solenoid.	Unscrew solenoid, pull out the plunger and the spring from the solenoid and clean them. Use scale remover material if needed. When replacing the plunger, please make sure that the spring is in vertical position.	
		2. The central orifice in the diaphragm is plugged or the diaphragm is torn	Clean the orifice or replace diaphragm.
		3. The water supply pressure is higher than 8 bar.	Reduce the supply water pressure.
		4. The water supply pressure is under 8 bars and yet the pressure in the faucet's body is higher. This situation could be caused by a sudden increase in the water supply pressure that the backcheck prevents from dropping, even after water supply pressure drops under 8 bars.	Shut off water supply and unscrew one of the flexible pipes in order to reduce the pressure that blocks the product.
Water flow from spout does not stop:	1. Sensor flashes once when user's hands are within the sensor's range.	1. Debris or scale in diaphragm	Clean the orifice or replace diaphragm.
		2. Connectors between the electronic unit and the Dual power input box are disconnected or not connected properly	Connect the connectors properly. Refer to page 6 to see how.
	2. Red light in the sensor does not flash once when user's hands are within the sensor's range.	1. Sensor is dirty or covered.**	Clean or eliminate cause of interference.
		2. Sensor is picking up reflections from the washbasin or another object.	Decrease the range or eliminate cause of reflection.
Water flow diminished		Filter or aerator is clogged	Remove, clean, re-install

* "Security Mode": If the sensor is covered for more than 90 sec. the faucet will automatically shut off water flow. To return to normal operation remove any blockage.

** In this case, the water flow will stop anyway after 90 seconds because of the security time.



Dolphin Solutions Ltd

Southpoint, Compass Park, Bodiam,
Robertsbridge, TN32 5BS

Tel: +44 (0)1424 20 22 24

Fax: +44 (0)1424 205 200

info@dolphinsolutions.co.uk

www.dolphinsolutions.co.uk