



DSI22

# DOLPHIN WALL PLATE MOUNTED INFORM (SMART) TAP

## INSTALLATION AND MAINTENANCE GUIDE

### PRODUCT CODES

DSI22.100	> 100mm Projection
DSI22.125	> 125mm Projection
DSI22.150	> 150mm Projection
DSI22.175	> 175mm Projection
DSI22.200	> 200mm Projection
DSI22.225	> 225mm Projection
DSI22.250	> 250mm Projection
DSI22.275	> 275mm Projection

## DSI22

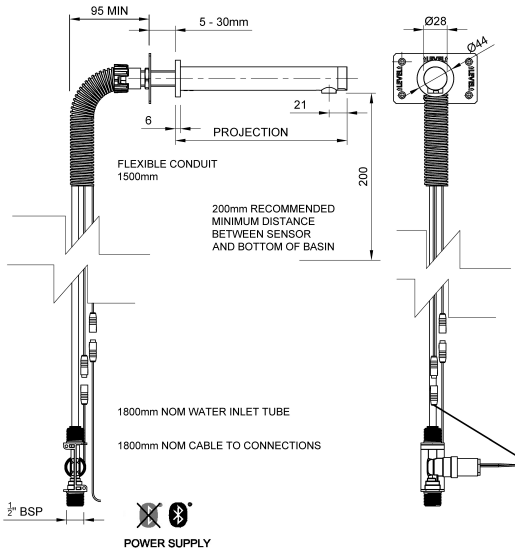

### TECHNICAL DATA

- › Dolphin Wall Plate Mounted InForm (SMART) Straight Body Tap
- › Manufactured from high-quality, highly durable 1.4401 (316) Marine grade stainless steel.
- › Self-Monitoring Analysis and Recording Technology (SMART) allows the Facilities Manager to connect point to point via the Dolphin SMART App when used with the optional Bluetooth Adaptor (Sold separately -Order product code 25148 )
- › Infra-Red Touch Free Tap for ultimate hygiene prevents cross contamination Sensor mounted in end of spout
- › Designed to be front mounted for when rear access installation is not possible
- › Flow rate – 3.0 litres/minute with the standard fitted flow regulator (fitted adjacent to solenoid) at any pressure between 0.5 and 6.0 bar
- › 1.0 - 4.0 litres/minute flow rates available to special order – please enquire
- › Water Supply: Single inlet cold or pre-mixed a TMV2 or TMV3 thermostatic mixing valve is recommended for premixed applications
- › Maximum operating water temperature - 60°C
- › Power Supply: \*\*
- › Nominal Current: Less than 1mA (Less than 25mA with Bluetooth)
- › Nominal Power: Less than 1W
- › Security Time can be adjusted via the App Default 20 Seconds (60 Seconds max)
- › IP68 Connector

\* See page 4 for power supply and other options

### PRODUCT CODES

DSI22.100	› 100mm Projection
DSI22.125	› 125mm Projection
DSI22.150	› 150mm Projection
DSI22.175	› 175mm Projection
DSI22.200	› 200mm Projection
DSI22.225	› 225mm Projection
DSI22.250	› 250mm Projection
DSI22.275	› 275mm Projection

### Coding Explained

#### Style

DSI22 - Wall Mounted  
DSI2X.XXX.X

#### Projection

100/125/150/175/200/225/250/275mm  
DSI2X.XXX.X

#### Finish

1 Brushed Satin  
2 Mirror Polished  
3 PVD Brushed  
4 PVD Mirror  
5 Powder Coated  
DSI2X.XXX.0

#### Colour

Suffix to end of code  
(Number allocated by Dolphin Solutions)

#### Example Coding DSI22.150.1

Wall Mounted  
150mm Projection  
Brushed Satin Finish

#### Options

Bluetooth   
PVD  
Powder Coating

## PACK CONTENTS

1	25036	Solenoid Adaptor Housing
2	25698	Solenoid
3	25035	1/2 Cartridge
4	25030	8mm Tube
5	25272	Straight Conduit Adaptor
6	25350	M20 1/2 Nut
7	25274	Lock Washer
8	25275	Tail
9	25618	Rosette
10	25624	Barbed Adaptor
11	25622	O-Ring
12	25621	M5x6 Grub Screw
13	25617	Body
14	25620	M5x6 Grub Screw
15	25626	M2.5x10mm Screw
16	25627	Adaptor for Sensor Cap/Aerator
17	25579	Sensor Assembly
18	25625	Sensor Cap
19	25623	Sealing Washer
20	DB4430580000	Aerator
21	25619	Aerator Housing
22	25276	Conduit

### Options



✓ ? Order 25148 separately

Standard



Bar  
0.5 min  
6.0 max

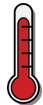

°C  
60 ✓



3L/min

## PRE INSTALLATION

› Please check that all the components in the list above are present and that they are in good condition before installation. If any components are missing contact Dolphin Solutions.

### ⚠ WARNING

› Highly reflective surfaces directly beneath the sensor of this product, in particular polished finish basin wastes/strainers, will cause false activation of the infrared sensors and can result in malfunction. We recommend Satin or Matt finish products which can be found on our website.

› Sitting water may also cause the tap to activate

› All Plumbing and Electrical installation must be carried out by a qualified person and in accordance with applicable codes and regulations.

› Do not kink the water supply hose.

## INSTALLATION

1 Flush pipes thoroughly before and after installation

2   
 Ø40

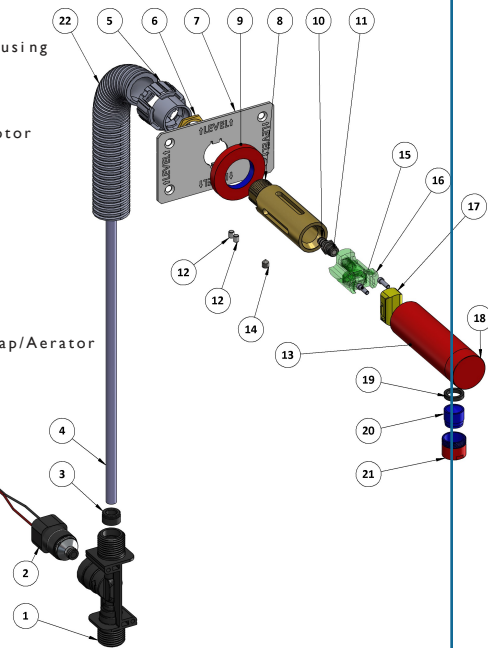

3

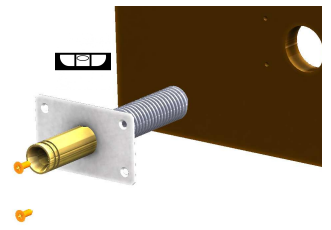

Fix the wall Tail/Mounting Plate assembly with 4 screws supplied. Ensure wall plate is level as this dictates tap angle and rotation. Protect Brass Tail with low tack tape / other suitable method

4

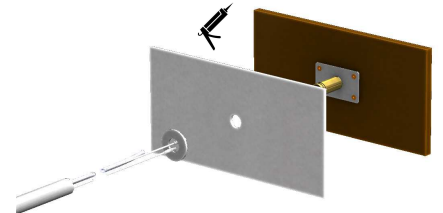

Fit Splashback with adhesive (or other fixing method as required) leaving mounting assembly protruding (Ø21min hole)

Insert in order - plugged cables and then pipe from the tap into mounting assy and feed through. **DO NOT** Remove connectors from cable or pipe ends until after they have passed through the conduit.

5

Remove Protective tape from tail. Fit Rosette (if required) over mounting assembly. Slide tap body onto mounting assy and secure with grub screws from beneath



6



1/2" BSP

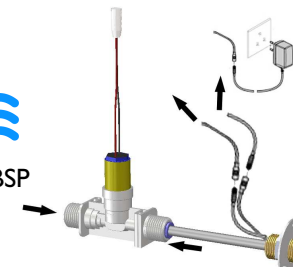

7

› Switch on power supply

› The sensor is self adjusting.\*

\*Further adjustments can be made by purchasing the Bluetooth Adaptor and downloading the App

8



Open hot and cold water supply and check that connections are watertight.

## MAINTENANCE

**DO NOT** use steel wool or cleansing agents containing alcohol, acid, abrasives or the like. Use of any prohibited cleaning or maintenance products or substances could damage the surface of the tap. For surface cleaning of tap use **ONLY** soap and water then wipe dry with a clean soft cloth. Protect taps from splattering of harsh cleansers when cleaning surroundings.

## OPTIONS

### POWER SUPPLY OPTIONS

**UK MAINS ADPATOR PRODUCT CODE 25147**  
(Other Adaptor pin and power supply configurations available, see below for part numbers):

- › Input voltage: 100 - 240V AC +/- 10%, 50 - 60 Hz
  - › Output voltage: 6.75V DC + 0.15V/ -0.35 V
  - › Secondary current: 0 - 350 mA DC
  - › Buffer capacitors: The adaptor secondary contains 3 buffer capacitors (necessary to close the solenoid valve in case of power outage):
    - 2 x 2200 µF,
    - 1 x 100µF
- Certifications: EN 60335-1, EN 60950-1
- › 1m Cable

**HARDWIRE TRANSFORMER PRODUCT CODE 25240**

- › Input voltage: 100 - 240V ± 10% 50-60 Hz ± 3 Hz
  - › Output voltage: 6.6V DC ± 5%
  - › Secondary current: 200 mA DC
  - › Buffer capacitors: one buffer capacitor 4700 µF (necessary to close the solenoid valve in case of power outage)
- Certifications: EN 60335-1, EN 61558-2
- › 1m Cable (Transformer to Tap), 2m Cable (Transformer to Mains)

**BATTERY PACK PRODUCT CODE 25241**

- › Requires a 6V lithium battery (CR-P2, approx. 1.500mAh) which has a lifetime of 200.000 switching cycles or 3-5 years depending on user frequency.

- › 100mm Cable (Approx)

- › **Important note** - the battery unit can't be used in combination with the Bluetooth adaptor.

The battery unit contains the CR-P2 battery as delivery content. The housing enables a fixation on wall by using the mounting clips (part of the housing but screws are not included) or the rear affixed Velcro tape

Power Supply Options:  
25147 UK Mains Adaptor  
25428 EURO Mains Adaptor  
25240 Hardwire Transformer  
25241 Battery Pack

### BLUETOOTH ADAPTOR PRODUCT CODE 25148



Bluetooth® version 4.0.

The **current version** of the app required for using the system **must** be installed on the control unit in advance. The App is available for free in the iTunes Store (requires an Apple account) and the Google Play store (requires a Google account).

For operation under adverse environments, in buildings / rooms with reinforced concrete walls, steel and iron frame, or near of obstructions (eg furniture) of metal, the Bluetooth reception can be disturbed and interrupted.

#### **Bluetooth®:**

Power consumption:	Less than 25mA
Output:	Bluetooth® - Class 2
Bluetooth® - version:	4.0
Bluetooth® - Transmission distance: (depending on the environments)	about 10m
Automatic safety shut-off:(10/20/60 seconds - adjustable)	20 s
Run-on time (0 - 10 s adjustable):	1 s
Detection Range - Levels 1 to 10 (10 = 120mm approx)	10