

02.4011

# **DOLPHIN HIGH SPEED HAND DRYER**

---

## **User Manual**



Please read carefully before use



## PRODUCT DATA

- › **Operating Voltage**  
240VAC 50-60Hz 0.8-1.0kW
- › **Output Warm Air Volume**  
42-60 CFM (71-102 m<sup>3</sup>/h) Adjustable
- › **Output Warm Air Temperature**  
131°F (55°C) at ambient T = 77°F (25°C), Adjustable
- › **Output Air Speed**  
102mph (150ft/s) [45.5m/s {164km/h}] – 157mph (230ft/s) [70m/s {252km/h}] Adjustable
- › **Sound Level**  
68.9 dB-A Min @ 2m, 74.3 dB-A Max @ 2m, Adjustable
- › **Motor Type**  
0.67HP, 16-29krpm Brush Type, Dual Ball Bearings, Adjustable
- › **Motor Thermal Protection**  
240VAC, Auto Resetting Thermostat turns unit off @ 203°F (95°C)
- › **Heater Element**  
ON/OFF Heating options: Range Adjustable, 325-500W
- › **Heater Thermal Protection**  
Auto Resetting Thermostat turns heater element off @ 185°F (85°C), Resets @ 167°F (75°C), Thermal cut-off @ 288°F (142°C)
- › **Drying Time**  
Less than 15 seconds
- › **Standby Power**  
Less than 0.5W
- › **Circuit Operation**  
Infrared Automatic, self-adjusting
- › **Sensor Range**  
Standard 152mm ±20mm (6")
- › **Timing Protection**  
60 seconds auto shut off
- › **Timing Duration**  
1 second delayed turn off after last sensor reading
- › **Cover Type**  
1.2mm 1.4301 (304) stainless steel
- › **Net Weight**  
8.5Kg

Data varies depending on motor speed and heater element on/off

## PRODUCT DESCRIPTION

Recess mounted high speed hand dryer:

Model number 02.4011 with flush mounted lock, vertically brushed stainless steel door and dryer bowl and stainless steel back box.

Rated: 240VAC, 50-60Hz, 0.8-1.0kW, IP23.

Manufactured by Dolphin Solutions Ltd.

### IMPORTANT SAFETY NOTES

This product is not intended for use by persons who are disabled, who lack the necessary knowledge and experience or children less than 8 years of age, unless they have been given instructions on how to use the product and are supervised by a person who is responsible for their safety.

Children shall not play with this appliance.

The dryer cover must only be removed by a qualified electrician. Ensure power is switched off to the unit before removing cover.

# PRODUCT DATA

Input VAC	Motor		Heater	Total	
	Inrush A(W)	Operating A(W)	Inrush/ Operating A(W)	Inrush A(W)	Operating A(W)
220	2.86 (630)	1.91 (420)	1.91 (420)	4.77 (1050)	3.82 (840)
230	2.99 (689)	2.00 (459)	2.00 (459)	4.99 (1148)	3.99 (918)
240	3.13 (750)	2.08 (500)	2.08 (500)	5.21 (1250)	4.17 (1000)

## MECHANICAL INSTALLATION:

- › Recommended wall opening for proud mounting: 360w x 431h x 112d
- › Position the unit into the prepared wall recess allowing a 6mm clearance all around the unit for packing and adjustment.
- › Open door panel of dryer using key provided.
- › Remove and retain 2 cover screws from underside of internal dryer casing, remove casing.
- › Provide supply wire in accordance to local wiring regulations to hole location in rear of back box and attach securely to chassis with suitable cable gland (May differ to that supplied)
- › Fit temporary screws into slots on side walls. Do not fully tighten screws into wall to allow for horizontal adjustment.
- › Fix casing to surrounding structure using suitable screws. Pack and adjust as necessary to ensure unit is square and level. Do not over tighten screws or the unit casing may become distorted. Remove temporary screws from slots.
- › Re-fit internal dryer casing and re-fit retained screws.
- › Close and lock door

## ELECTRICAL INSTALLATION:

### WARNING

- › Disconnect power at the service breaker before installation or servicing
- › A qualified electrician must install this product. It is recommended that this unit be checked every 6 months
- › All units must be supplied with a 3-wire service. The earth wire must be connected to the dryer's back plate
- › The means of disconnection must be in the fixed wiring in accordance with the correct electrical regulations

### DANGER

- › Failure to properly ground unit could result in severe electrical shock and/or death.
- › Open door panel with suction cup provided. Door is right hand hinged.
- › Remove and retain 2 cover screws from underside of internal dryer casing, remove casing
- › Provide supply wire in accordance to local wiring regulations through suitable cable gland (May differ to that supplied) in rear and attach securely to chassis
- › The hand dryer must be supplied from the mains (220-240 volt supply) via a suitably rated double pole isolation switch with at least 3mm air gap in each pole.
- › Connect supply and ground wires to terminal block where indicated or connect supply wires to terminal block where indicated and connect ground wire to base with ground screw
- › Re-fit internal dryer casing and re-fit retained screws (Do not overtighten)
- › Close door

## MAINS CABLE CONNECTIONS AS FOLLOWS:

- › Red or Brown wire to Live terminal marked "L".
- › Black or Blue to Neutral terminal marked "N".
- › Green or Yellow and Green to Earth terminal marked "⏚" or to the green screw marked "⏚".
- › Bare grounding earth wires should be sleeved with green and yellow tubing. Colours of live and neutral wires depend on voltage of supply service and requirements of Building and Electrical Code having jurisdiction.

**Service Tool included** Security hex driver 4mm (5/32" pin-hex will work if tool is lost).

## RECOMMENDED MOUNTING HEIGHTS

From top edge of dryer aperture to finished floor level

› Men	1270
› Women	1195
› Children 4-7 years	890
› Children 8-10 years	990
› Children 11-13 years	1090
› Children 14-16 years	1195
› Handicapped	1015

## OPERATION

- › Shake excess water from hands
- › To activate dryer place hands in dryer bowl and repeatedly turn hands over until dry. Heater has built in safety thermal cut off. Sensor has 1 second inactivity cut off.

## CARE AND MAINTENANCE

**Periodic cleaning of the unit is recommended to ensure optimum performance.**

- › Clean with soap and warm water; dry with a clean soft cloth.
- › To maintain finish of stainless steel parts use any industrial steel cleaner; polishing along the material grain with a clean soft cloth.
- › Internal cleaning; **Disconnect the electrical supply.**
- › Remove the two cover mounting screws
- › Remove the cover
- › Clean all dust/lint from the interior of the dryer.
- › Replace the cover. Do not over tighten the screws.
  
- › **Never Use Corrosives - such as bleach or other cleaning products containing hypochlorite;**
- › **Any form of acid solution or industrial cleaning solution; Bathroom cleaning products, developer liquids, concentrated disinfectants, strong alkalis or caustic soda;**
- › **Never Use Abrasives – such as wire wool; scouring pads;**
- › **Caution – Never use dirty or grit contaminated cleaning sponges or cloths**

## TROUBLESHOOTING

Symptom	Corrective Action for Installation Failures
Dryer will not run	First ensure that the breaker supplying the dryer is operational. If it is, disconnect the power and remove the dryer cover. Taking suitable precautions to avoid shock hazard, reconnect the power and check for Voltage at the terminal block. Verify that connections are made correctly.
Dryer cycles by itself or runs constantly	Ensure that there is no obstruction on or in front of the IR sensor. Clean any dirt or debris off the sensor lens. If problem persists, replace sensor.
Dryer makes a loud noise and does not run for a complete cycle	Ensure that the supply Voltage is correct. Dryer will make a loud humming noise if the input Voltage is too high. Verify Voltage requirement on the unit rating label and correct supply as required. If CBM has been damaged replace CBM, IR sensor module.
Dryer runs but the air stream is low pressure and/or low velocity	Ensure that the supply Voltage is correct. Dryer will run weakly if the input is too low. Verify Voltage requirement on the unit rating label and correct supply as required.
Symptom	Corrective Action for In-Service Failures
Dryer will not run	First ensure that the breaker supplying the dryer is operational. If it is, disconnect the power and remove the dryer cover. Replace CBM, IR sensor module. Taking suitable precautions to avoid shock hazard, reconnect the power and check for Voltage at the terminal block.
IR sensor only "sees" close range objects	Ensure that there is no obstruction on or in front of the IR sensor. Clean any dirt or debris off the sensor lens. If problem persists, disconnect the power and remove the dryer cover and replace CBM, IR sensor module.
Heater gets hot but no air stream is produced	Disconnect the power. Remove the dryer cover. Check VR for speed setting. Disassemble the blower-motor/fan housing. Replace the fan motor. Reassemble.
Dryer only blows cold air during a full cycle	Disconnect the power. Remove the dryer cover and check/ensure heater SW is ON. Disassemble the blower-motor fan housing. Test the thermostat for open circuit. Check the heater element for signs of burning or breakage. Damaged element must be replaced.
Air stream is low pressure and velocity	Check the output nozzle for obstructions. If none are present, disconnect the power. Remove the dryer cover. Remove any dust/lint build up from intake vent slots. Check VR for speed setting. Disassemble the blower-motor/fan housing. Check the motor brushes for worn condition ( $\leq 30\text{mm}$ graphite remains) and replace them, if necessary.

# REPAIR PARTS LIST TO HAND DRYER

Key	Description	Qty	Key	Description	Qty
1	Blower housing - Upper	1	19	CAUTION label	2
2	Motor rubber – Upper	1	20	Security hex cap head ¼"-20 x 5/8" screw with lock washer	1
3	Motor brushes	2	21	Cable protector	1
4	Motor 0.67HP@240Vac	1	22	Screw M4 x10, Philips pan head	2
5	Heater assembly 500W@240Vac, I   5.2Ω	1	23	Self threading screw M4 x 10, Philips pan head	8
6	Blower housing – Lower	1	24	Screw M3 x 16, Philips pan head	2
7	Motor rubber – Lower	1	25	Screw M4 x 10, Philips pan head with external tooth lock washer	1
8	Base plate	1	26	Screw M5 x 8, Philips pan head with external tooth lock washer	2
9	Grounding screw with cup washer	1	27	Screw M5 x 10, Philips pan head	2
10	Mylar shield with LNG marked	1	28	Wire Harness (Not shown)	1
11	Nylon cable clamp	1	29	L-Wrench	1
12	Terminal block	1	30	CBM terminal legend label	1
13	Blower mounting bracket	1	31	Rating label	1
14	Circuit Board Module (CBM)	1	32	Caution Branch Circuit Label 7.5A-240Vac/277Vac	1
15	Sensor bracket	1			
16	Sensor module	1			
17	Label, circuit diagram	1			
18	Cover	1			

### Air Speed:

Switch power off. Loosen cover screws and remove cover. Use small Philips head screwdriver to turn VR shaft. Clockwise to increase power to max. Counter clockwise to reduce power.

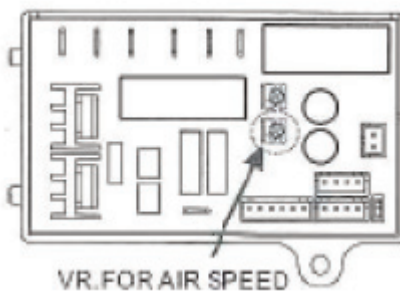

### Heater:

Switch power off. Loosen cover screws and remove cover. Adjust the heater switch on the PCB with a small plastic or wood flat blade probe.

Heater on = "ON"

Heater off = "I"

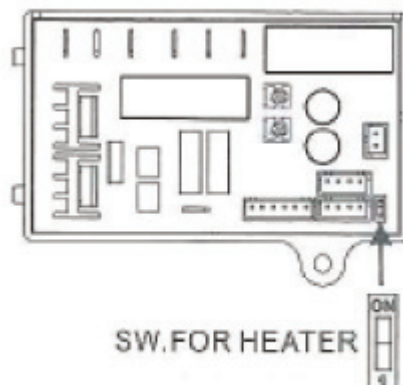

### Factory Set Sensor:

Adjustable range 100-230mm

Clockwise to increase range

Counter clockwise to decrease range

Do not overturn!

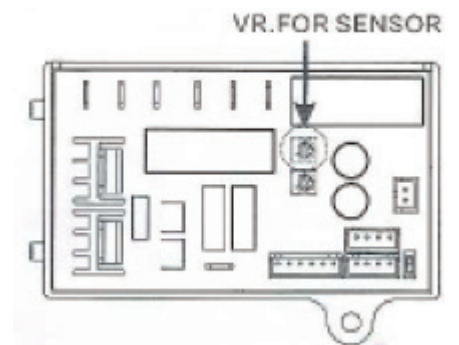

# REPAIR PARTS LIST TO HAND DRYER

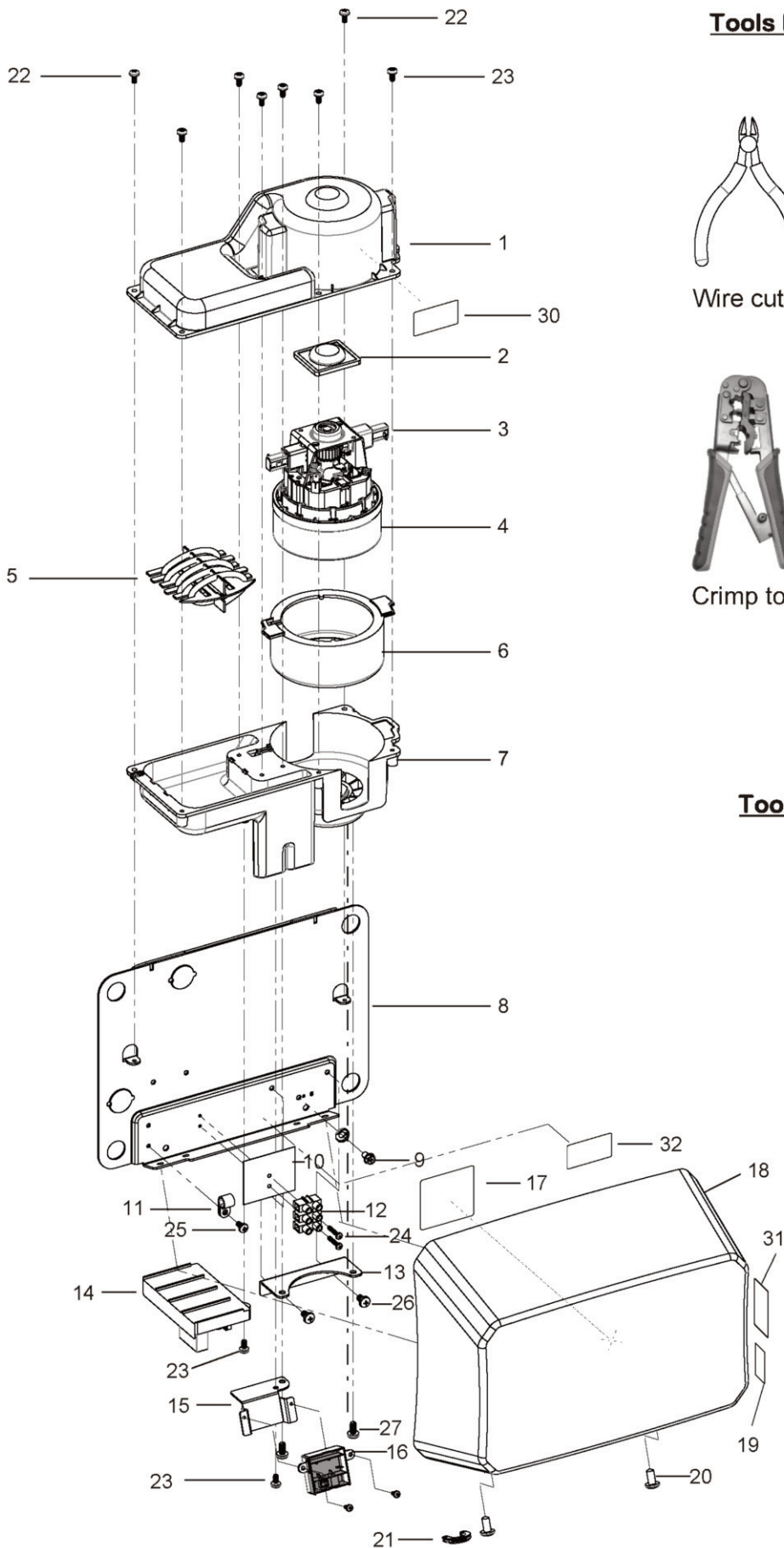

## Tools Required (Not provided)

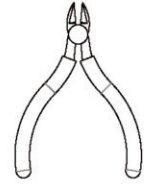

Wire cutter



Philips #1/ #2



Crimp tool

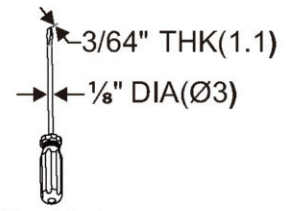

Flat blade

## Tools Required (Provided)



L-Wrench  
Item 29

## SPECIFICATION

- › Recess mounted high speed hand dryer. Model number 02.401 I with flush mounted lock, vertically brushed satin finish stainless steel door and dryer bowl and stainless steel back box. Rated: 220-240V, 50-60Hz, 0.8-1.0kW, IP23. Manufactured by FC Frost Ltd.

N.B. For surface mounted version order 02.441 I



## MATERIAL

- › Door: 1.2mm satin finish stainless steel grade 1.4301 (304) to BS EN 10088-1
- › Bowl: 0.7mm satin finish stainless steel grade 1.4301 (304) to BS EN 10088-1
- › Back box: 0.9mm stainless steel grade 1.4301 (304) to BS EN 10088-1

## WARRANTY

- › This product is covered by a 12-month warranty from the date of purchase to be free from defects if installed and maintained in accordance with these instructions. Dolphin Solutions will replace or repair (as appropriate) free of charge any product with a proven manufacturing defect if reported within the warranty period.

- › Meets SKA rating Criteria for Energy Efficient Hand Dryers ID E24. This product falls within the scope of the Waste Electrical & Electronic Equipment Regulations Directive (WEEE). This product should not be disposed of with household waste. Please recycle where facilities exist or contact Dolphin Solutions Ltd for further assistance. Check with your local authority for further recycling advice

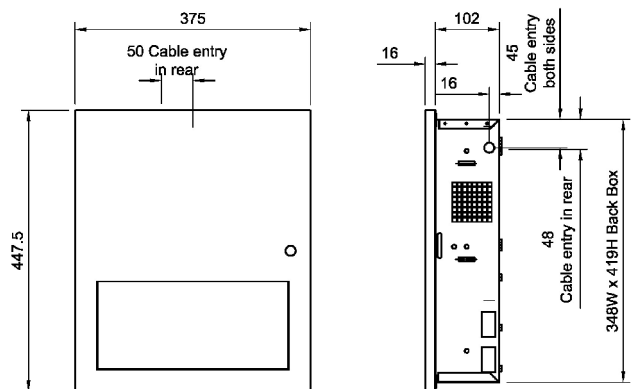

## Dolphin Solutions

Southpoint, Compass Park, Bodiham, Robertsbridge TN32 5BS

Tel: 01424 202224

Fax: 01424 205200

www: [dolphinsolutions.co.uk](http://dolphinsolutions.co.uk)

info@[dolphinsolutions.co.uk](mailto:dolphinsolutions.co.uk)

