

BC 101-ES Dolphin Prestige Titan Changing Unit and Liner Roll Dispenser

User Manual

Please read carefully before use



INSTALLATION INSTRUCTIONS

SAFETY BABY CHANGING TABLE

Read the Installation Instructions Thoroughly Before Commencing Installation

The design of the safety baby changing table makes it easy to mount in even very small rooms. The changing table must be mounted onto a wall which is suited to carry the weight of the table as well as a baby – preferably a solid wall!

Where To Mount the Baby Changing Table

Determine the ideal place to mount the baby changing table. Keep in mind that the depth of the changing table is 625 mm in open position. The distance from the floor to the lower edge of the table mountings should be approx. 750 mm (see FIG. 1). Doorways, sinks etc. should of course also be taken into consideration when choosing where to mount the changing table.

IMPORTANT: Do NOT mount the table in a chlorine-containing environment!

Marking and Drilling Holes

To mount the changing table onto brick, gas concrete or the like, use 10 mm screws and matching universal plastic dowels – e.g. Fischer fixings type S-12.

When mounting the changing table onto a cavity wall of min. 16 mm (or 2 x 13 mm) plaster board, we recommend prior mounting of a reinforcement plate of stainless steel, plywood or the like, onto which the changing table is subsequently mounted. Attach reinforcement plate to the wall using a considerable number of special metal cavity fixings, Fischer part. no. BC 62328 or equivalent (part. no. BC 62315 for double plate). The changing table itself is also mounted with these screws and dowels – plus one metal washer per screw hole. For further details, please refer to the instructions of the dowel supplier.

In places where plaster walls have not yet been finished, we suggest mounting a 16 mm plywood board on the inside of the plaster wall, rendering the need for a reinforcement plate on the outside unnecessary.

Mark and drill holes as indicated on FIG. 1. The top holes for the table mountings should be drilled into solid brick - not into a joint.

IMPORTANT: Be sure to drill the holes for the mountings exactly vertically underneath each other, or the pneumatic shock absorbers inside the mountings may break!

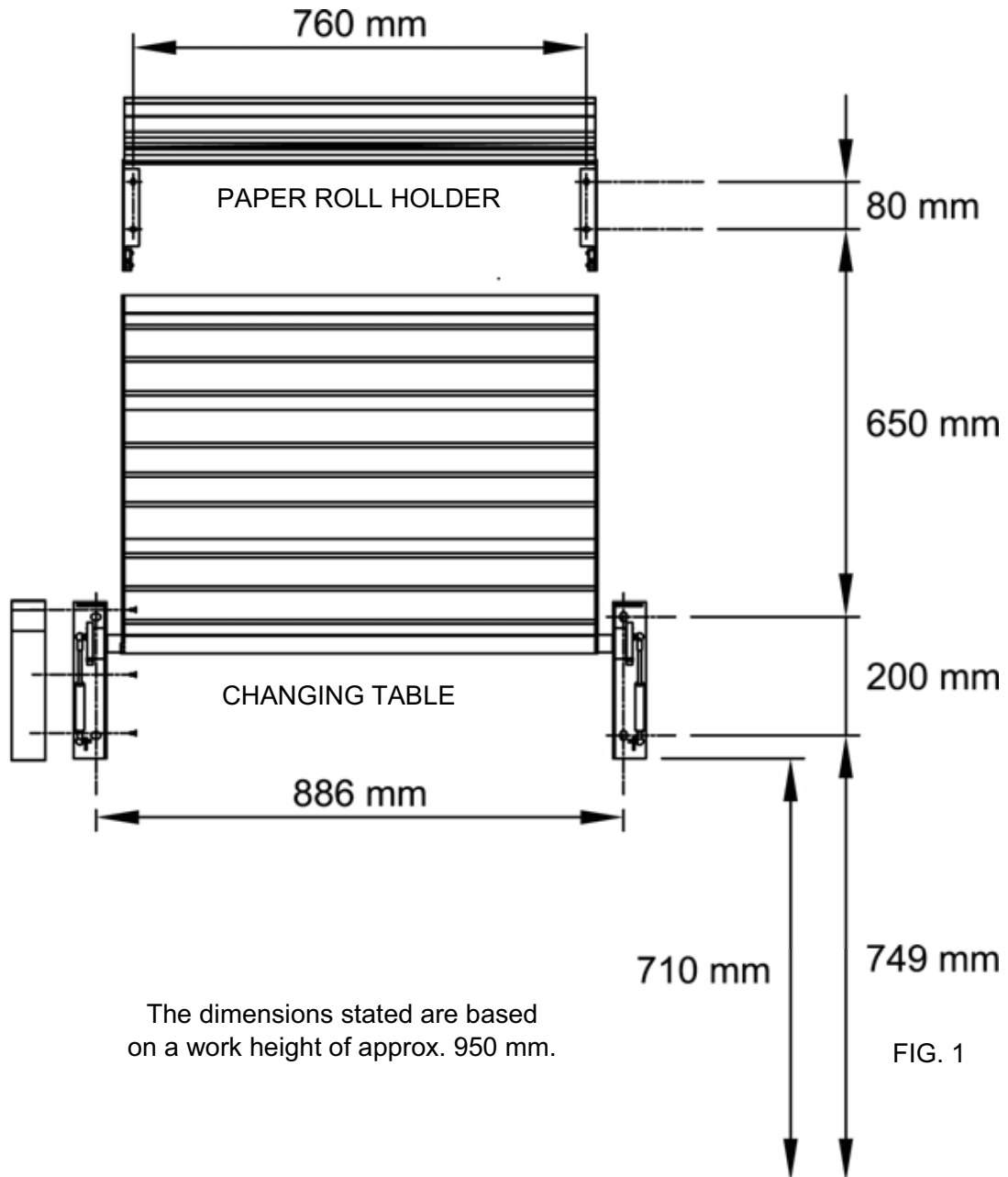

MOUNTING THE BABY CHANGING TABLE

- ❶ Disassemble the cover plates of the table mountings by removing the 6 screws (3 on each) with a Torx screwdriver no. 20.
- ❷ Mount the table onto the wall, making sure that it is completely level.
- ❸ The changing table is factory pre-adjusted to easily close when given a slight push from open position.
- ❹ Check that the changing table is mounted solidly onto the wall.
- ❺ Check that the shock absorbers can pass freely when opening and closing the table.
- ❻ Reassemble the cover plates onto the mountings.

Components

MOUNTING PAPER HOLDER

The paper holder consists of the following parts:

1 holder
Left-side mountings with lock
Right-side mountings
2 keys

- ❶ Mark and drill holes as indicated on FIG. 1.
- ❷ Fix the mountings onto the wall with 6 mm screws and plugs suited for the wall type onto which the paper holder is to be mounted.
- ❸ Place a paper roll loosely in the paper holder and tip the holder towards the wall, making the white locking devices click.

Components

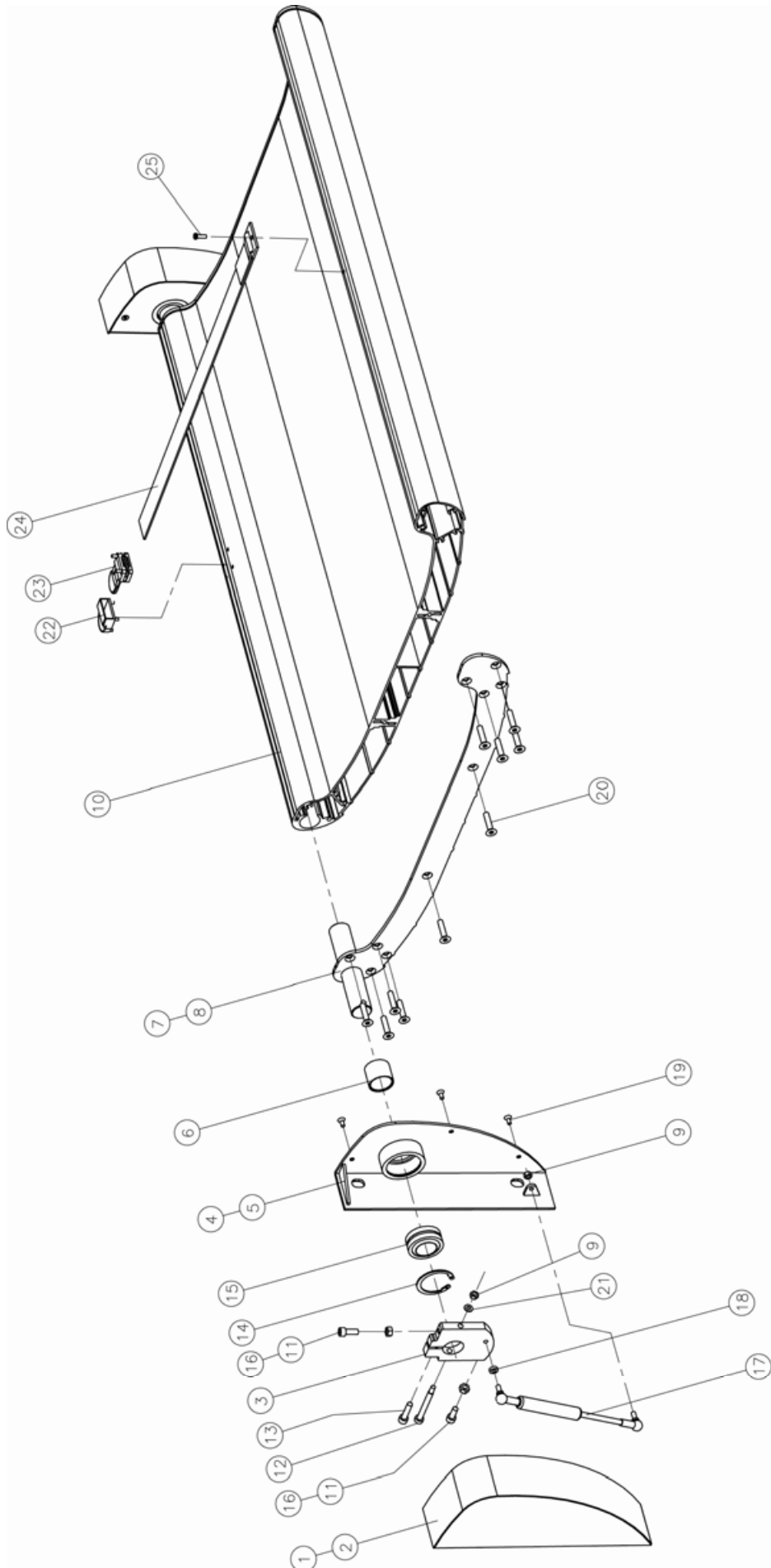

Spare Parts

Position No.	Part No	Description
1	BC 65524	Hood for mounting bracket, complete, left
2	BC 65525	Hood for mounting bracket, complete, right
3	BC 65541	Crank
4	BC 65546	Mounting bracket, complete, left
5	BC 65547	Mounting bracket, complete, right
6	BC 65534	Spacer Ø25 mm, for spindle
7	BC 65531	End flange, left
8	BC 65532	End flange, right
9	BC 20040	Nut M5, stainless, self-locking
10	BC 65516	Aluminium table-top, 790 mm, white
11	BC 20038	Nut M6, stainless
12	BC 20047	Tight-fitting bolt M5 6x60 mm
13	BC 20041	Allen bolt, stainless, M6 x 25 mm
14	BC 20057	Locking ring Ø40 DIN 472
15	BC 65562	Spherical bearing
16	BC 20042	Allen bolt for crank (setscrew), stainless, M6 x 16 mm
17	BC 65402	Gas spring, 330 N, (Bansbach)
	BC 65407	Gas spring, 350 N, (Scandiloc)
	BC 65406	Gas spring replacement set with crank, screws etc.
18	BC 20065	Spacer, polyamide, Ø5.2 x Ø10 x 3 (only for installation with part. no.: 65402)
	BC 20855	Spacer, nylon, Ø5.3 x Ø10 x 1 (only for installation with part. no.: 65407)
19	BC 20044	Screw, countersunk, stainless, M4 x 10, torx
20	BC 20053	Screw, stainless, M6 x 20 mm, torx
21	BC 20835	Spacer, flat, stainless, A2, M5 x 10
22+23+24	BC 65551	Safety belt complete with buckle
25	BC 40068	Screw, stainless, M4 x 12 mm, torx
	BC 65520	Measuring band
	BC 65630	Pictogram, door

Bell-Chem Products Company

Haywood Way, Hastings, TN35 4PL

Tel: 01424 202224

Fax: 01424 205200

www: dolphindispensers.co.uk

info: info@dolphindispensers.co.uk

