

BC100SS Horizontal Nappy Changing Unit Installation Instructions



WARNING

- Failure to follow these warnings and the installation instructions could result in serious injury or death.
- Read all instructions before installing diaper changing station. Keep these instructions. **DO NOT** discard.

ASSEMBLY INSTRUCTIONS

ADULT INSTALLATION REQUIRED.

TOOLS REQUIRED:

- Level (A)
- Measuring tape (B)
- Power drill (C)

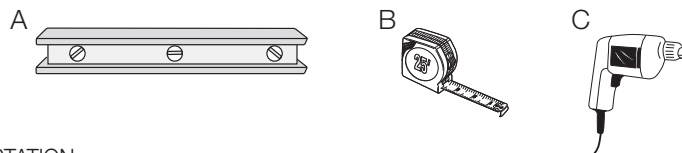

- READ ALL INSTRUCTIONS BEFORE ASSEMBLY OF DIAPER CHANGING STATION
- Unpack carton and identify all parts.

⚠ WARNING

- This changer has six (6) recess mounting holes.
- The diaper changing station is no stronger than the anchors or walls to which they are attached and, therefore, MUST be firmly secured in order to support the weight they are intended to support. It is recommended that this unit be installed in a recessed fashion. If surface mounting, contact an architect, building contractor, or Professional Engineer for proper installation and hardware. Contact an architect or building contractor if any questions.
- Child should never be left unattended.
- Avoid serious injury from falling or sliding out. Always use restraint system.
- Adding excessive weight such as parcels, packages, or accessories to the unit or to the bag hooks that exceed the total weight limit of 50 pounds (22.7 kg) may cause the unit to be unstable or may cause a hazardous unstable condition to exist.

PARTS LIST

Parts Description	Quantity
Door / Wall Plate	1

IMPORTANT: Due to widely varied wall material, anchoring to be determined by architect or engineer.

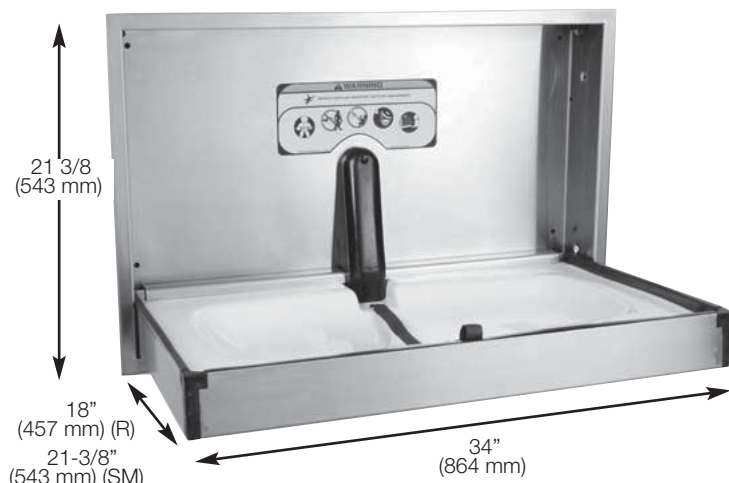

Door / wall plate to be mounted on outside of restroom door.

A.D.A. Compliance:



- 4.4.1 Maximum Protruding Objects
 - 4.2.5 Forward Reach
 - 4.2.6 Parallel Approach
 - 4.27.4 Operation
- Compliant when properly installed.

OPERATION:

Rotate base downward. Place infant on top of the changing surface. Use restraint system as described below. After child has been changed, remove restraint system and rotate base back up against the wall.

USE OF RESTRAINT SYSTEM:

Place child so restraint strap is located at abdomen. Rotate top of buckle upward and insert strap in buckle. Pull strap through buckle until snug against infant. Rotate top of buckle downward to lock the strap into place. Slide red locking tab over top of buckle (Fig. a). Reverse steps to loosen strap.

MAINTENANCE AND CLEANING:

Check all hardware and components monthly or as required to ensure hardware is tight and there are no missing or damaged components. Take unit out of service if any component is missing or damaged and contact customer service to order replacement parts. Do not substitute parts. For replacement parts, contact customer service at 0800 0723 404.

Clean by using a damp cloth with mild soap or mild multi-purpose cleaner. Do not use any strong chemical cleaners or cleaning agents that may be hazardous to children.

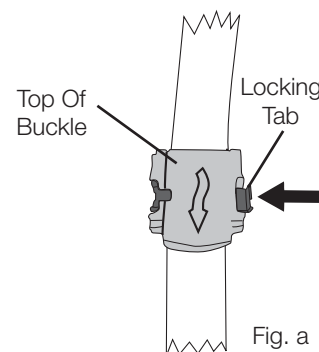

INSTALLATION - RECESSED

For A. D. A. compliance, top of lower double stud should be 30.5" (78 cm) from the floor.

Recommended Blocking:

Wood double stud blocking is necessary. Contact an architect and building official to make sure the blocking is adequate and complies with building codes (Fig b) .

1. Slide changer into blocking area and mark mounting hole location on blocking studs.
HINT: This may require 2 additional people to help hold changer in position while you are marking the locations.
2. Shim changer for a snug fit.
3. Align holes in changer with marked holes and secure using the appropriate fasteners (Fig. c) .

NOTE: It is installers responsibility to provide correct fasteners for other substrates.

4. Ensure all six (6) fasteners are tight.

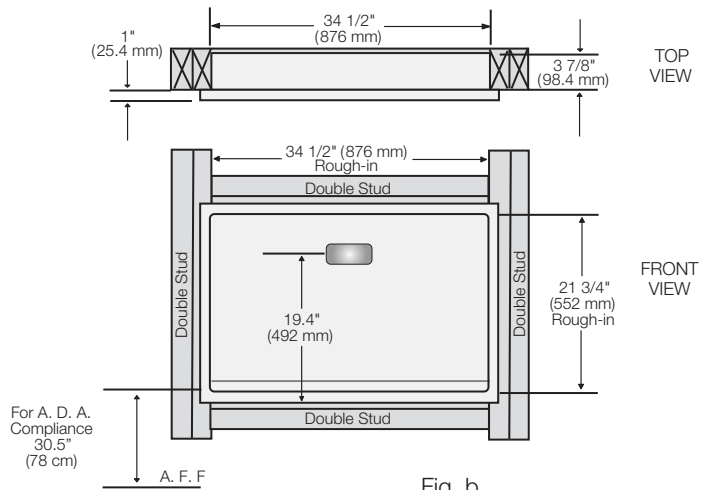

Fig. b

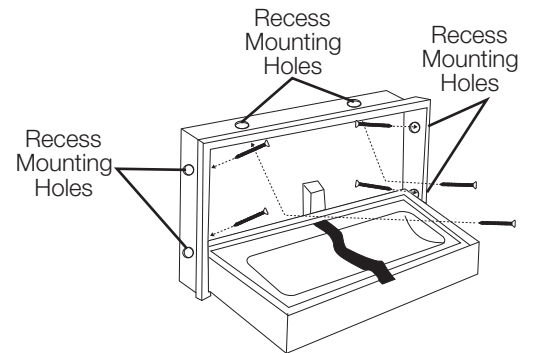

Fig. c

INSTALLATION - SURFACE-MOUNT

Recommended Blocking:

If the walls do not have studs on center, then additional blocking is necessary (Fig. d) .

Contact an architect or building contractor to make sure the blocking is adequate and complies with building codes.

For A. D. A. compliance, measure up 50 1/4" (128 cm) from the floor and mark the wall. This locates the position for the top left attachment hole.

NOTE:

- Changer MUST be mounted to studs (Fig. e) .
- This unit incorporates a finishing collar that seats behind the changer's outside flange. Center the collar as the unit is being tightened against the wall (Fig. f) .

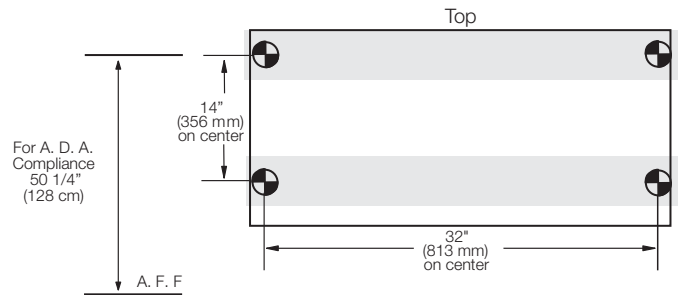

Fig. d

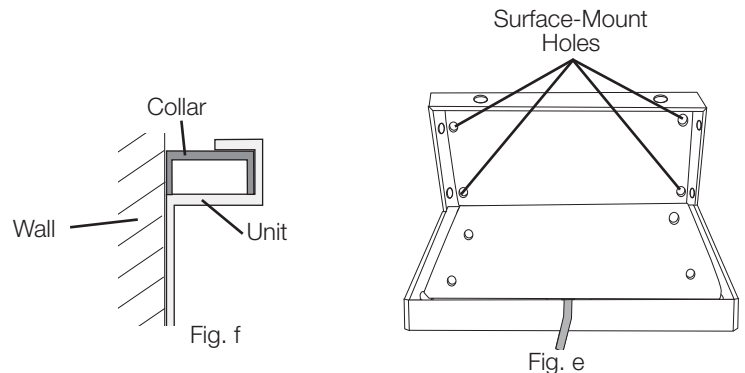

Fig. f

Fig. e

0800 0723 404

Bell-Chem Products Company
Haywood Way, Hastings, TN35 4PL

info@dolphindispensers.co.uk
www.dolphindispensers.co.uk

